

General Instructions (con't.)

INSTALLING THE NEW FRAME KIT

1. If you are installing a right/left pair, repair one side at a time, keeping a reference/measuring point.
2. Support vehicle completely over a solid, level floor. Use good quality, weight-rated, safety jack stands, ramps or ideally – a hydraulic lift.
3. Most of our kits are designed to slip over the original frame after the bottom of the frame rust is cut back, and then welded in place. This helps duplicate the original dimensions, and location points, which can be lost if sections are completely removed. This overlapping SafeTCap® technique is the way we have been successfully repairing frames for over 40 years, providing superior strength while allowing you to complete the job safely and quickly.
4. The bottom of the frame must be cut off and area ground to clean metal – at least half way up the frame. With this method the frame rust is not contaminating your new frame section. The minimum remaining can be no less than 1/2" of the original frame for the SafeTCap® kit to overlap and perform as designed. Measure, fit, measure, then tack weld SafeTCap® at key points, the final installation requires complete 100% edge welding with an assistant acting as a Fire Watch.
5. Some frames have brackets, bumps, stops, etc. that need to be cut off and reused in order to complete the installation. Drill out the factory spot welds on these for cleanest removal.
6. Once welding and wire brushing is finished, brush or spray primer, then paint or undercoating.
7. Inspect the repair yearly.

SAFETCAP® ONE YEAR LIMITED WARRANTY

What Does This Limited Warranty Cover?

This warranty covers any SafeTCap® product defect or malfunction in your new frame repair component.

How Long Does The Coverage Last?

This warranty lasts one (1) year from the date of purchase and is nontransferable.

What Will SafeTCap® Do?

SafeTCap® will replace any defective part at no charge. You must pay shipping and all labor charges to remove and reinstall the defective part.

What Does This Limited Warranty Not Cover?

This limited warranty applies to the SafeTCap® frame repair components only, and covers any defects in materials and workmanship on the component. SafeTCap® is not responsible for product failure due to improper installation, or installation on modified frames and vehicles with non-standard retrofitted suspensions. SafeTCap® is not responsible for the quality of the

installation, or for any issues that may arise beyond the scope of repair for which the part was intended.

Consequential and incidental damages are not recoverable under this warranty. Some states do not allow the exclusion or limitation of incidental or consequential damages, so the above limitation or exclusion may not apply to you.

How Does State Law Apply?

This warranty gives you specific legal rights; you may also have other rights which vary from state to state.

How Do You Get Warranty Service?

In order to be eligible for service under this warranty, you must return the SafeTCap® registration card provided, within 30 days of receipt. You may also register your SafeTCap® online at www.safetcap.com. To obtain warranty service, please call us toll free at 1-800-407-7024.

SafeTCap® products are designed and developed by SafeTCap Inc. in response to hundreds of vehicles that have required frame rot repairs. All kits/parts have been developed, manufactured, tested and installed at our Cranston, Rhode Island, USA facilities.

We accept returns within 30 days of receipt of product. Buyer pays return shipping and is subject to a 10% RESTOCKING FEE. To return an order customers need to call 1-800-407-7024 to obtain a RETURN AUTHORIZATION NUMBER. We do not accept returns that have been modified or altered, in any way, from the factory shipped component.

Copyright ©2017 SafeTCap Inc., all rights reserved. SafeTCap® is a registered trademark of SafeTCap Inc. and is not affiliated with any vehicle manufacturer for which its products are intended. SafeTCap® products are not endorsed by any vehicle manufacturers as OEM frame repair. Jeep, Wrangler, CJ, YJ, TJ, and the Jeep Grille Design are registered trademarks of Fiat Chrysler Automobiles (FCA). SafeTCap Inc., has no affiliation with FCA. Throughout our product line brochures the terms "Jeep," "Wrangler," "CJ," "YJ," and "TJ" are used for identification purposes only.



We Make it Easy to Make it Safe!

SafeTCap®
1550 Elmwood Ave.
Cranston, Rhode Island 02910
(401) 944-4444 (800) 407-7024
www.safetcap.com
(USA)

ART-138 & ART-145 Installation

Floor Channel Sub-Frame Kits

Jeep 1997-2006 Wrangler TJ



ART-145 Full Length Floor Channel Sub-Frame

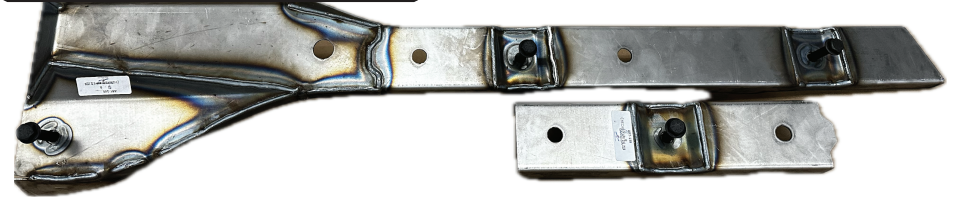

ART-138 Center Bodyto Frame Mount

The Jeep Wrangler body is attached to the frame by 3 bolts on each side of the vehicle. The bolts pass through the body mounts on the main frame and screw into the floor channel sub-frame, welded to the underside of the floor. The sub-frame is susceptible to corrosion and appears most frequently at the center mount first and our SafeTCap® ART-138 fixes that issue. If your entire floor channel sub-frame is in need of replacement, the SafeTCap® ART-145 will do the trick. Both kits come with replacement mounting bolts. Once installed our SafeTCap® kits will restore your Jeeps original solid feel.

CAUTION! If you are not fully confident doing the installation yourself, have a professional welder install it, or at least have one inspect your repairs before you finish coat your Safe-T-Cap™ installation.

1. IMPORTANT: Read and understand the "General Instructions for Installing SafeTCap® Frame Repair Kits" before you begin.
2. Before you prepare to remove your body mount, it is a good idea to place 1-1/4" spacers between the frame and the floor to prevent the floor from sagging especially near the back two body mounts. (Blocks made from pressure treated decking work well.) You can skip this procedure if you are installing the ART-138.
3. For the ART-138 remove center body mount bolt on the floor channel sub-frame. For the ART-145 remove all three bolts on the floor channel sub-frame.
4. Pull back floor mats directly over floor channel.
5. Cut off frame mounts (only the center frame mount for 138 kit). [Illustration – A]
6. Leave an area 1/2" smaller than kit on top and ends.
7. Place ART-138 or ART-145 into position.
8. Realign new ART-138 or ART-145 floor channel kit, and original (or buy new) body mount(s) with our supplied body mount bolts.
9. Tack weld kit in place, with an assistant acting as a Fire Watch.
10. Inspect alignment with body mounts.
11. Finish welding, with an assistant acting as a Fire Watch. [Illustration – B]
12. Tighten body mount bolts to 50 ft. lbs.
13. "Happy trails" and Drive Safe!

ART-138 & ART-145 Installation Floor Channel Sub-Frame Kits



1997-2006 Wrangler TJ

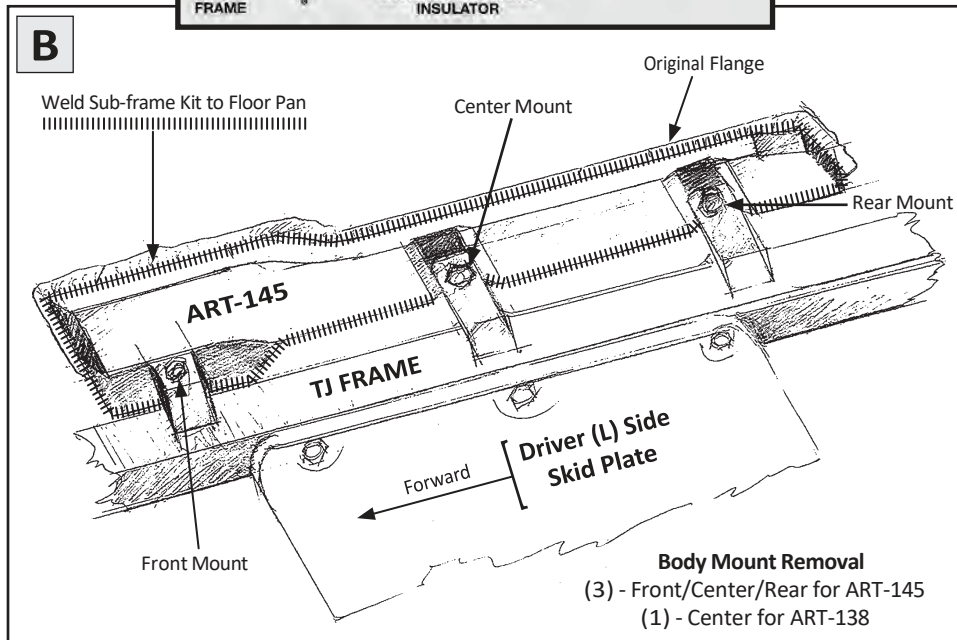
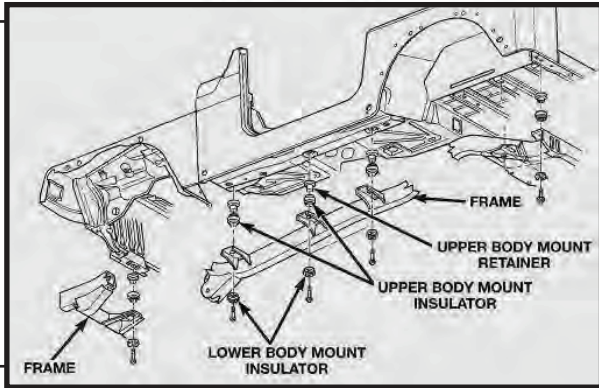
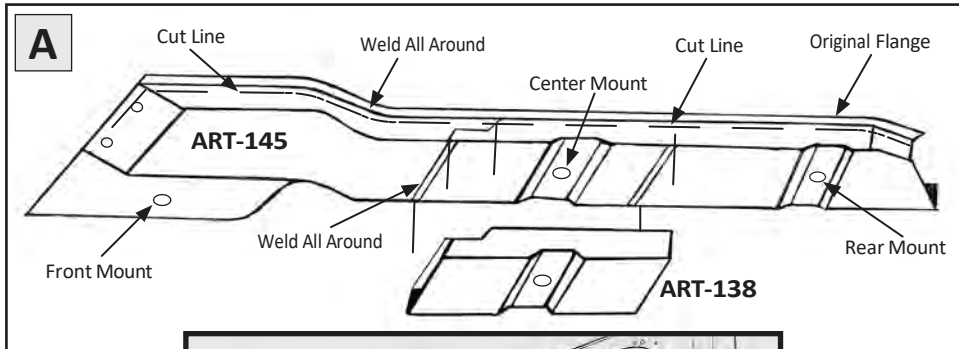

ART-138 & ART-145

(2)

General Instructions for Installing SafeTCap® Frame Repair Kits

General automotive welding safety, metal preparation,
and frame repair guidelines to achieve long-lasting results – safely.

Attention! For your safety follow all instructions. Failure to follow instruction may result in property damage or serious or fatal injury. User assumes all liability.

EQUIPMENT LIST

- Jack Stands/Ramps/Lift
- Quick Line Disconnect
- Eye & Ear Protection
- Work Gloves
- Fire Extinguisher & Water
- Cutting Wheel or Torch
- Grinder or Sander
- Locking Pliers or Clamps
- Welder: Mig or Stick
- Paint & Undercoat

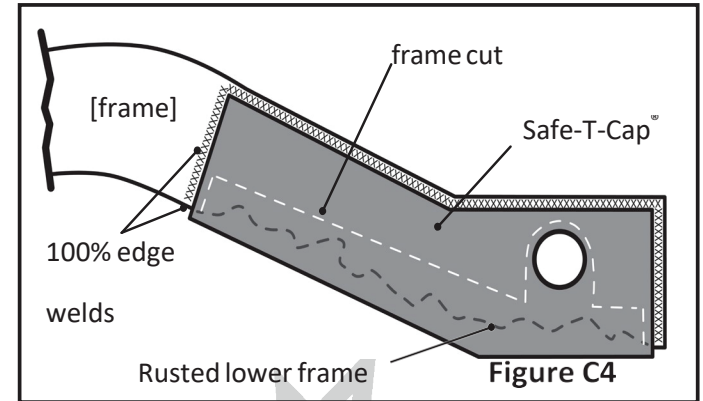

VEHICLE PREPARATION

1. Disconnect the battery.
 2. Check for fuel leaks; tank > lines > engine.
 3. Repair or replace any leaky fuel lines before proceeding any further.
 4. If the fuel tank leaks, remove it before, repair/replace after installation is complete.
 5. Remove fuel tank if within 24" of the welding/repair area.
 6. Keep flammable materials at least 20' from the vehicle.
 7. Remove interior panels, seats, padding and carpets in the cabin area above work area.
 8. Keep a fire extinguisher and water hose close by, use water for any fabric fires.
 9. ALWAYS use a Fire Watch Person when cutting or welding on a vehicle. In case of emergency, call 911 immediately.
- > General Instructions con't. on page 4



We Make it Easy to Make it Safe!

SafeTCap® products are Registered Trademark Designs developed by SafeTCap Inc. in response to hundreds of cars, Jeeps and trucks that have required frame rot repairs. All kits/parts have been designed, manufactured, tested and installed in our Cranston, Rhode Island, USA facility.

SafeTCap® Inc. is always looking for high quality regional repair facilities to recommend for installations. If you are a repair shop and would like to be on our installation referral list, please call 800-407-7024 or email our new business opportunity coordinator at office@autorust.com.

(3)