

ART-139 & 139HD Installation Instructions

Forward Shock and Fuel Tank Support Crossmember

1999-2006 Silverado/Sierra 1500, 1500HD, 2500 & 2500HD

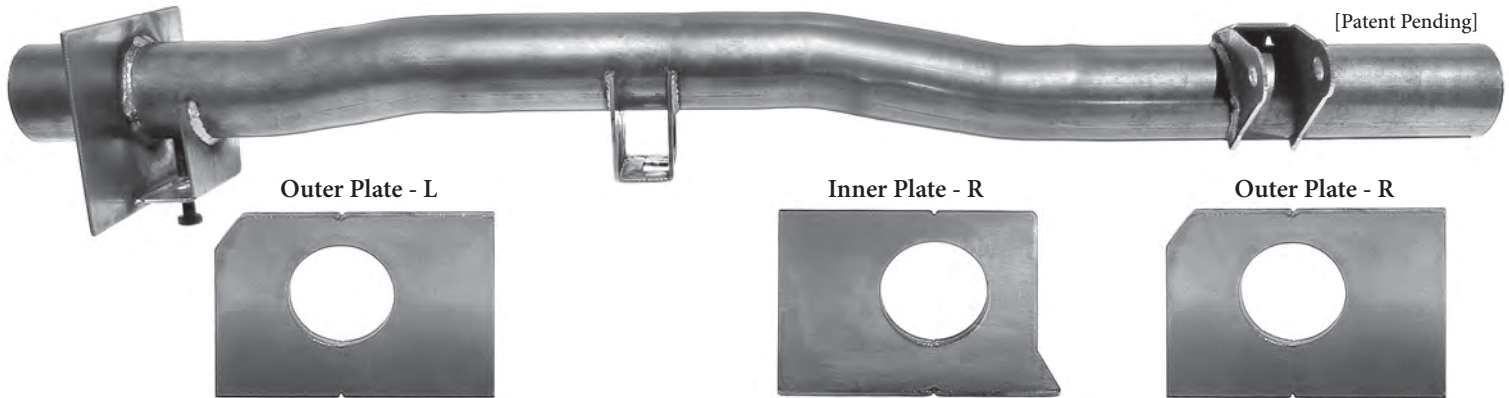

Your new ART-139/139HD SafeTCap® Forward Shock and Fuel Tank Support Crossmember is designed to be a direct replacement for the crossmember that came on your truck. The ART-139 is constructed using 3" diameter, .120" thick, mandrel bent tubing and 11 ga. mounting components (7 ga. shock mount on HD).

Pre-welded on the crossmember are the left side inner mount plate the right side upper shock mount, the fuel tank strap bracket, and fuel tank support with a 10mm x 3" bolt included. The two outer end plates and right side inner mount plate are supplied loose for easy installation, as the truck bed is to be left on.

CAUTION! If you are not fully confident doing the installation yourself, have a professional welder install it, or at least have one inspect your repairs before you finish coat your SafeTCap® installation.

ART-139 INSTALLATION (STEPS 1-13 of 34)

1. **IMPORTANT:** Read and understand the "General Instructions for Installing SafeTCap® Frame Repair Kits" before you begin.
2. Prepare truck by running the fuel as low as possible in the tank to decrease the weight of the tank.
3. Support the truck on at least two heavy duty jack stands under the rear axle, create as much room as possible to work safely. Level frame left to right. Two additional jack stands on the frame forward of the rear axle will add extra stability and support.
4. Remove the two rear tires.
5. Remove rubber fuel filler hose, a 5/16" socket is required.
6. Disconnect the rear shock from the upper mount bracket.
7. Place a floor jack under the fuel tank to support it during its removal.
8. Disconnect the two fuel lines. You will need a 3/8" and 5/16" "Quick Line Disconnect" available at any auto parts store. Clamp off or plug lines to avoid fuel leaks and fumes.
9. Unbolt the support straps that hold the fuel tank in place
10. Lower the fuel tank out from the frame and move the tank away from the vehicle.
11. Mark the vertical center line of the original crossmember on the outside face of both the left and right frame rail. Extend the line to the underside of each frame and up the inner side. (Illustrations - 1 & 2)
12. Make marks on the outside of your frame to ensure correct positioning of the new crossmember by tracing the outside end plates on the outside frame face. Mark the area around the original cross tube to be cut on both the inside and outside of the two frame rails. (Illustrations - 1 & 2)
13. Next, remove the old crossmember by cutting the frame around the 3" tube following your markings on all 4 frame faces; inside and outside on both sides of the frame. [Steps 14-34, continued on page 2]



If you are interested in becoming a Dealer/Installer of the SafeTCap® Product Line - Call Jerry @ 800-407-7024 (ext. 606) or 401-368-6211.

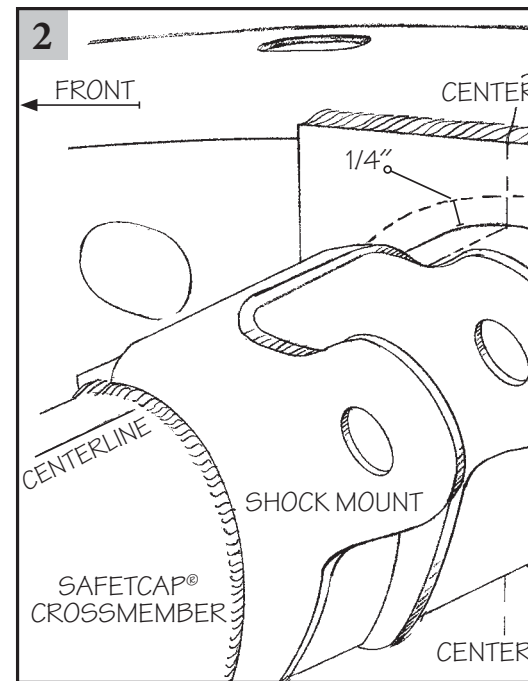
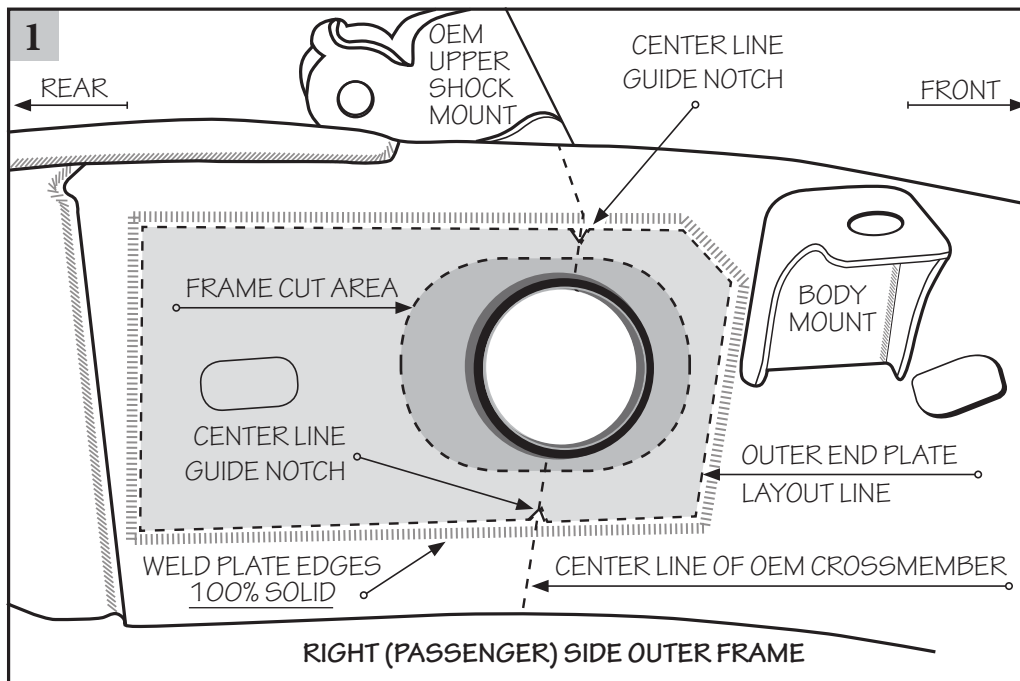

ART-139 INSTALLATION (STEPS 14-34)

14. Inspect your ART-139 repair kit and prepare to position it so that the shock mount is on the passenger side of the truck, on top of the tube and facing the rear bumper. The fuel tank mounts are facing down on the driver's side of the truck. (Illustration – 3)
15. To test fit your ART-139, lift your crossmember into position by sending the shock mount end over the driveshaft, then sliding the right side inside mount plate onto the 3" tube.
16. Next slide the crossmember through the right side frame as far as it will go.
17. Lifting the left side up, aligning it with the hole in the left frame, slide it through the frame until the inner mount plate is flat against the truck frame. (Illustration – 3)
18. Place the outside end plate onto the crossmember tube ends and clamp the entire assembly onto position by lining the plates up with the end plate outline and center line marks. (Illustration – 1)
19. Check the fit, make sure shock mount and gas tank mounting brackets are positioned correctly.
20. **IMPORTANT:** *Brake lines and wiring must route above the ART-139.*
21. Remove the ART-139 and use an abrasive wheel or heavy grinding disc to clean the areas to be welded on all 4 frame faces. Be careful to preserve your location marks.
22. Install your ART-139 back into position.
23. When satisfied with crossmember location, tack weld the end plates.
24. Weld entire perimeter of the outer plates.
25. Weld entire perimeter of the inner plates.
26. Remove exhaust strap from the old cross tube and reinstall on the new ART-139.
27. Weld the entire circumference of the tube as it passes through the end plates. (R inside, R/L outside).
28. Double check your welds.
29. Prime and paint your new SafeTCap® Kit.
30. Reinstall the fuel tank and fuel lines.
31. Reinstall the shocks.
32. Start engine and check for fuel leaks.
33. Double check all bolts.
34. Bolt wheels back on, lower vehicle to ground, and you're back on the road again!

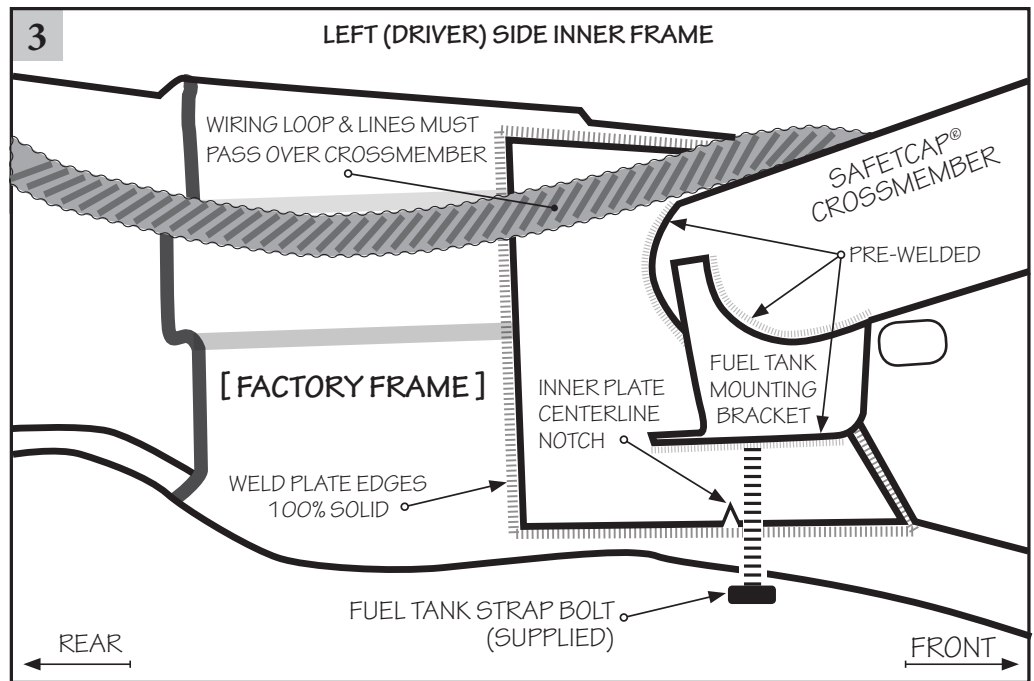
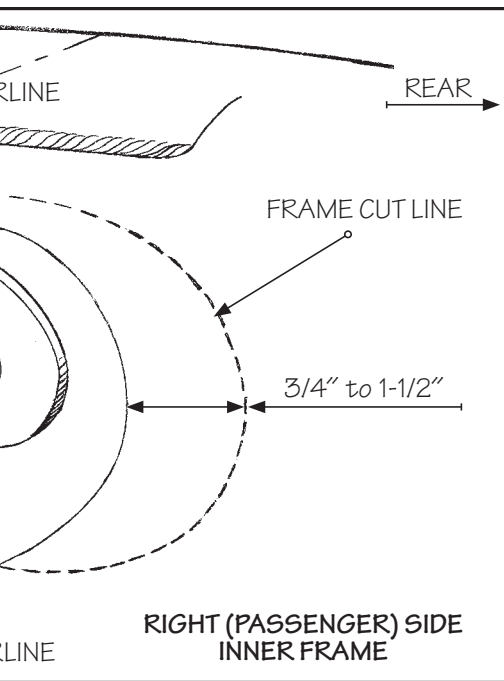

General Instructions for Installing SafeTCap® Frame Repair Kits

General automotive welding safety, metal preparation, and frame repair guidelines to achieve long-lasting results – safely.

Attention! For your safety follow all instructions. Failure to follow instruction may result in property damage or serious or fatal injury. User assumes all liability.

VEHICLE PREPARATION

1. Disconnect the battery.
2. Check for fuel leaks; tank > lines > engine.
3. Repair or replace any leaky fuel lines before proceeding any further.
4. If the fuel tank leaks, remove it before, repair/replace after installation is complete.
5. Remove fuel tank if within 24" of the welding/repair area.
6. Keep flammable materials at least 20' from the vehicle.
7. Remove interior panels, seats, padding and carpets in the cabin area above work area.
8. Keep a fire extinguisher and water hose close by, use water for any fabric fires.
9. ALWAYS use a Fire Watch Person when cutting or welding on a vehicle. In case of emergency, call 911 immediately.

WELDING & SAFETY

1. Take safety precautions by wearing eye protection, gloves, sturdy boots, etc.
2. "Stick" or "arc" welding is difficult for some, but capable of producing a sound weld. For best old/new metal results, use 6011, 3/32" or 1/8" welding rods.
3. "MIG" welding produces a very sound weld. At Auto Rust Technicians we use 220v units with .035 wire (E7056) with a 75% Argon/25% CO2 gas mixture.
4. Quality welds require clean surfaces; so grind, scrape or wire brush surfaces to be welded – the minimum frame temperature for welding is 50°.
5. Weld kit in place using 1/2" to 1" long beads every 1", then weld seams solid.
6. If in doubt about the techniques, equipment and skills needed for a safe and successful installation call (800)407-7024 for an appointment to install your kit at our Cranston, R.I. location, or to obtain a list of installers near you.

EQUIPMENT LIST

- Jack Stands/Ramps/Lift
- Quick Line Disconnect
- Eye & Ear Protection
- Work Gloves
- Fire Extinguisher & Water
- Cutting Wheel or Torch
- Grinder or Sander
- Locking Pliers or Clamps
- Welder: Mig or Stick
- Paint & Undercoat

[General Instructions, continued on page 4]

**ART-139 & 139HD
Forward Shock &
Fuel Tank Support
Crossmember**

[View from Rear Bumper]

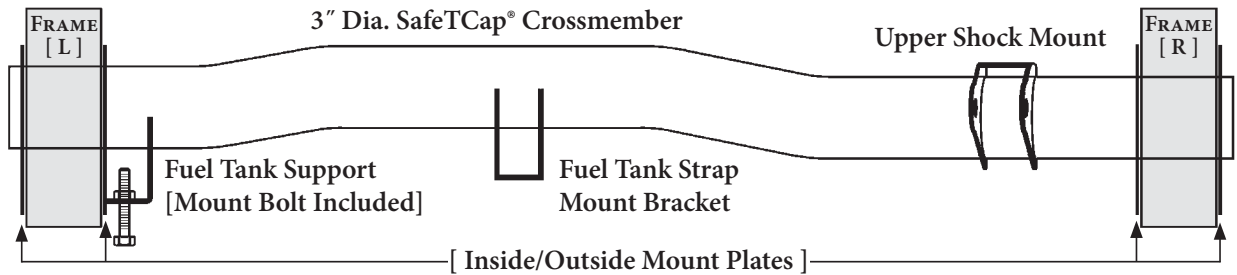

GENERAL INSTRUCTIONS (CON'T.) - INSTALLING THE NEW FRAME KIT

1. If you are installing a right/left pair, repair one side at a time, keeping a reference/measuring point.
2. Support vehicle completely over a solid, level floor. Use good quality, weight-rated, safety jack stands, ramps or ideally – a hydraulic lift.
3. Most of our kits are designed to slip over the original frame after the bottom of the frame rust is cut back, and then welded in place. This helps duplicate the original dimensions, and location points, which can be lost if sections are completely removed. This overlapping SafeTCap® technique is the way we have been successfully repairing frames for over 40 years, providing superior strength while allowing you to complete the job safely and quickly.
4. The bottom of the frame must be cut off and area ground to clean metal – at least half way up the frame. With this method the frame rust is not contaminating your new frame section. The minimum remaining can be no less than 1/2" of the original frame for the SafeTCap® kit to overlap and perform as designed. Measure, fit, measure, then tack weld SafeTCap® at key points, the final installation requires complete 100% edge welding with an assistant acting as a Fire Watch.
5. Some frames have brackets, bumps, stops, etc. that need to be cut off and reused in order to complete the installation. Drill out the factory spot welds on these for cleanest removal.
6. Once welding and wire brushing is finished, brush or spray primer, then paint or undercoating.
7. Inspect the repair yearly.

SAFETCAP® ONE YEAR LIMITED WARRANTY

What Does This Limited Warranty Cover?

This warranty covers any SafeTCap® product defect or malfunction in your new frame repair component.

How Long Does The Coverage Last?

This warranty lasts one (1) year from the date of purchase and is nontransferable.

What Will SafeTCap® Do?

SafeTCap® will replace any defective part at no charge. You must pay shipping and all labor charges to remove and reinstall the defective part.

What Does This Limited Warranty Not Cover?

This limited warranty applies to the SafeTCap® frame repair components only, and covers any defects in materials and workmanship on the component. SafeTCap® is not responsible for product failure due to improper installation, or installation on modified frames and vehicles with non-standard retrofitted suspensions. SafeTCap® is not responsible

for the quality of the installation, or for any issues that may arise beyond the scope of repair for which the part was intended.

Consequential and incidental damages are not recoverable under this warranty. Some states do not allow the exclusion or limitation of incidental or consequential damages, so the above limitation or exclusion may not apply to you.

How Does State Law Apply?

This warranty gives you specific legal rights; you may also have other rights which vary from state to state.

How Do You Get Warranty Service?

In order to be eligible for service under this warranty, you must return the SafeTCap® registration card provided, within 30 days of receipt. You may also register your SafeTCap® online at www.safetcap.com. To obtain warranty service, please call us toll free at 1-800-407-7024.



FRAME REPAIR KITS

We Make it Easy to Make it Safe!

SafeTCap®

1550 Elmwood Ave.

Cranston, Rhode Island 02910 USA

(401) 944-4444 (800) 407-7024

www.safetcap.com

SafeTCap® products are designed and developed by SafeTCap Inc. in response to hundreds of vehicles that have required frame rot repairs. All kits/parts have been developed, manufactured, tested, and installed at our Cranston, Rhode Island, USA facilities.

We accept returns within 30 days of receipt of product. Buyer pays return shipping and is subject to a 10% RESTOCKING FEE. To return an order customers need to call 1-800-407-7024 to obtain a RETURN AUTHORIZATION NUMBER. We do not accept returns that have been modified or altered, in any way, from the factory shipped component.

Copyright ©2017 SafeTCap Inc., all rights reserved. SafeTCap® is a registered trademark of SafeTCap Inc. and is not affiliated with any vehicle manufacturer for which its products are intended. SafeTCap® products are not endorsed by any vehicle manufacturers as OEM frame repair. Silverado and Sierra are registered trademarks of General Motors Company LLC. SafeTCap Inc., has no affiliation with General Motors Company LLC. Throughout our product line brochures the terms "Silverado" and "Sierra" are used for identification purposes only.