

# ART-127 Installation Instructions

## Rear Upper Trailing Arm Mount



1997-2006 Wrangler TJ & LJ



The SafeTCap® ART-127 Rear Upper Trailing Arm Mount is designed to repair rusted out or damaged rear upper trailing arm mount brackets on 1997-2006 Jeep TJ & LJ Wranglers. The ART-127 is designed to be an OEM replacement and has been upgraded by using 7 gauge hot rolled steel. A new trailing arm mounting bolt and weld nut is also included. The ART-127 is CNC plasma cut, bent, and MIG welded in our own factory. The ART-127 comes in LEFT (Drivers Side) ART-127-L, RIGHT (Passenger side) ART-127-R and in SETS (L&R) ART-127-S. MADE IN USA.



**CAUTION!** If you are not fully confident doing the installation yourself, have a professional welder install it, or at least have one inspect your repairs before you finish coat your SafeTCap® installation.

1. **IMPORTANT:** Read and understand the “General Instructions for Installing SafeTCap® Frame Repair Kits” before you begin.
2. Jack up the rear of your Jeep, and support it on two quality jack stands.
3. Remove both rear wheels.
4. Using a floor jack support the rear axle assembly by placing the jack under the differential housing.
5. Unbolt and swing the upper trailing arm out of your way.
6. Cut away the old upper trailing arm mount.
7. Prep the area by grinding the surface of the frame to be welded to clean bare metal for a strong weld.
8. Observe the upper trailing arm mount on the opposite side.
9. Place location marks on the frame. Maintain a distance of 5 5/8” from the mounting bolt center of the lower trailing arm to the center of the weld nut on the ART-127. [See Illustration - A]
10. Set the kit in place, clamp it to the frame and compare it to the other side.
11. Swing the trailing arm into position and check that the fit is exact.
12. Lower the trailing arm and tack weld the ART-127 onto the frame.
13. Recheck the trailing arm fit once more, then lower it and weld the entire perimeter of the ART-127.
14. Paint or coat your repair.
15. Bolt the upper trailing arm into position.
16. Mount rear wheels.
17. Lower jack on rear axle.
18. Remove jack stands and lower your Jeep.
19. Recheck all nuts and bolts.
20. Test drive and check repair, recheck weekly.
21. Drive Safe!

# ART-127 Installation Instructions

Rear Upper Trailing Arm Mount • 1997-2006 Wrangler TJ & LJ

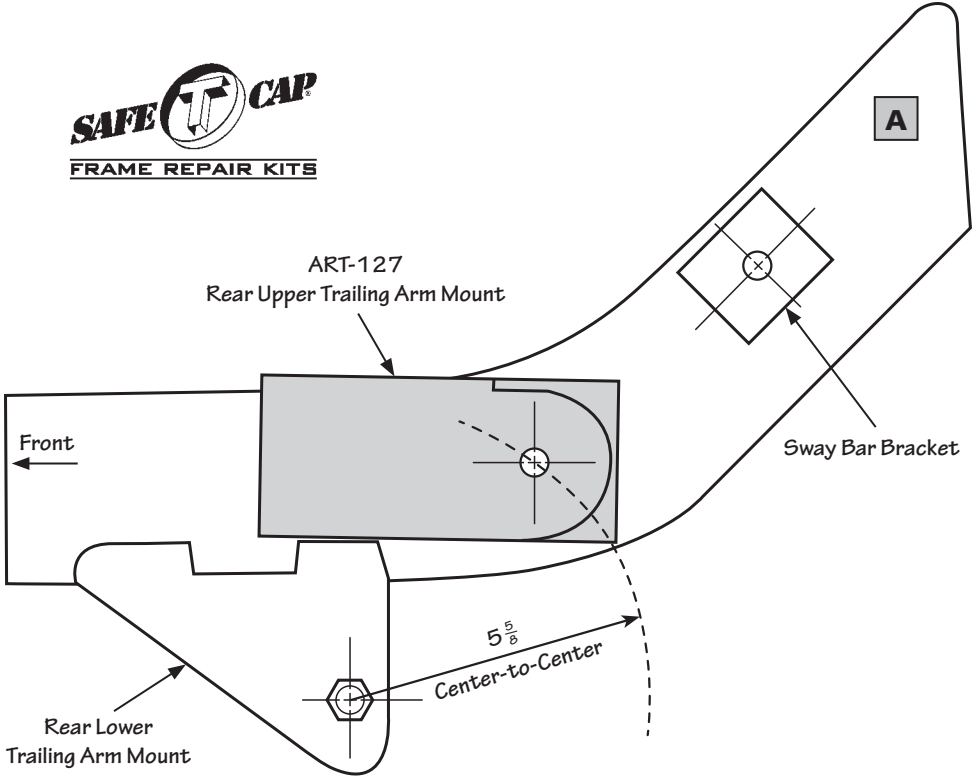

7 Gauge Hot Rolled Steel

Bolt Included

**ART-127-R**

Weld Nut Attached

# General Instructions for Installing SafeTCap® Frame Repair Kits

*General automotive welding safety, metal preparation, and frame repair guidelines to achieve long-lasting results – safely.*

**Attention! For your safety follow all instructions. Failure to follow instruction may result in property damage or serious or fatal injury. User assumes all liability.**

## EQUIPMENT LIST

- Jack Stands/Ramps/Lift
- Quick Line Disconnect
- Eye & Ear Protection
- Work Gloves
- Fire Extinguisher & Water
- Cutting Wheel or Torch
- Grinder or Sander
- Locking Pliers or Clamps
- Welder: Mig or Stick
- Paint & Undercoat

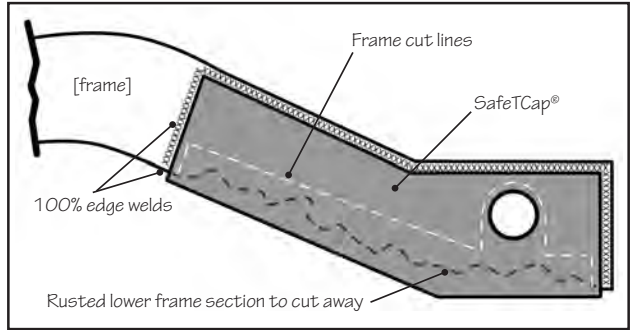

## VEHICLE PREPARATION

1. Disconnect the battery.
2. Check for fuel leaks; tank > lines > engine.
3. Repair or replace any leaky fuel lines before proceeding any further.
4. If the fuel tank leaks, remove it before, repair/replace after installation is complete.
5. Remove fuel tank if within 24" of the welding/repair area.
6. Keep flammable materials at least 20' from the vehicle.
7. Remove interior panels, seats, padding and carpets in the cabin area above work area.
8. Keep a fire extinguisher and water hose close by, use water for any fabric fires.
9. ALWAYS use a Fire Watch Person when cutting or welding on a vehicle. In case of emergency, call 911 immediately.

## WELDING & SAFETY

1. Take safety precautions by wearing eye protection, gloves, sturdy boots, etc.
2. "Stick" or "arc" welding is difficult for some, but capable of producing a sound weld. For best old/new metal results, use 6011, 3/32", or 1/8" welding rods.
3. "MIG" welding produces a very sound weld. At Auto Rust Technicians we use 220v units with .035 wire (ER70S-6) with a 75% Argon/25% CO2 gas mixture.
4. Quality welds require clean surfaces; so grind, scrape or wire brush surfaces to be welded – the minimum frame temperature for welding is 50°.
5. Weld kit in place using 1/2" to 1" long beads every 1", then weld seams solid.
6. If in doubt about the techniques, equipment and skills needed for a safe and successful installation call (800) 407-7024 for an appointment to install your kit at our Cranston, R.I. location, or to obtain a list of installers near you.

> continued on page 4

# General Instructions (con't.)

## INSTALLING THE NEW FRAME KIT

1. If you are installing a right/left pair, repair one side at a time, keeping a reference/measuring point.
2. Support vehicle completely over a solid, level floor. Use good quality, weight-rated, safety jack stands, ramps or ideally – a hydraulic lift.
3. Most of our kits are designed to slip over the original frame after the bottom of the frame rust is cut back, and then welded in place. This helps duplicate the original dimensions, and location points, which can be lost if sections are completely removed. This overlapping SafeTCap® technique is the way we have been successfully repairing frames for over 40 years, providing superior strength while allowing you to complete the job safely and quickly.
4. The bottom of the frame must be cut off and area ground to clean metal – at least half way up the frame. With this method the frame rust is not contaminating your new frame section. The minimum remaining can be no less than 1/2" of the original frame for the SafeTCap® kit to overlap and perform as designed. Measure, fit, measure, then tack weld SafeTCap® at key points, the final installation requires complete 100% edge welding, with an assistant acting as a Fire Watch.
5. Some frames have brackets, bumps, stops, etc. that need to be cut off and reused in order to complete the installation. Drill out the factory spot welds on these for cleanest removal.
6. Once welding and wire brushing is finished, brush or spray primer, then paint or undercoating.
7. Inspect the repair yearly.

## SAFETCAP® ONE YEAR LIMITED WARRANTY

### What Does This Limited Warranty Cover?

This warranty covers any SafeTCap® product defect or malfunction in your new frame repair component.

### How Long Does The Coverage Last?

This warranty lasts one (1) year from the date of purchase and is nontransferable.

### What Will SafeTCap® Do?

SafeTCap® will replace any defective part at no charge. You must pay shipping and all labor charges to remove and reinstall the defective part.

### What Does This Limited Warranty Not Cover?

This limited warranty applies to the SafeTCap® frame repair components only, and covers any defects in materials and workmanship on the component. SafeTCap® is not responsible for product failure due to improper installation, or installation on modified frames and vehicles with non-standard retrofitted suspensions. SafeTCap® is not responsible for the quality of the

installation, or for any issues that may arise beyond the scope of repair for which the part was intended.

Consequential and incidental damages are not recoverable under this warranty. Some states do not allow the exclusion or limitation of incidental or consequential damages, so the above limitation or exclusion may not apply to you.

### How Does State Law Apply?

This warranty gives you specific legal rights; you may also have other rights which vary from state to state.

### How Do You Get Warranty Service?

In order to be eligible for service under this warranty, you must return the SafeTCap® registration card provided, within 30 days of receipt. You may also register your SafeTCap® online at [www.safetcap.com](http://www.safetcap.com). To obtain warranty service, please call us toll free at 1-800-407-7024.



*We Make it Easy to Make it Safe!*

**SafeTCap®**

1550 Elmwood Ave.

Cranston, Rhode Island 02910

(401) 944-4444 (800) 407-7024

[www.safetcap.com](http://www.safetcap.com)

(USA)

SafeTCap® products are designed and developed by SafeTCap Inc. in response to hundreds of vehicles that have required frame rot repairs. All kits/parts have been developed, manufactured, tested and installed at our Cranston, Rhode Island, USA facilities.

We accept returns within 30 days of receipt of product. Buyer pays return shipping and is subject to a 10% RESTOCKING FEE. To return an order customers need to call 1-800-407-7024 to obtain a RETURN AUTHORIZATION NUMBER. We do not accept returns that have been modified or altered, in any way, from the factory shipped component.

*Copyright ©2018 SafeTCap Inc., all rights reserved. SafeTCap® is a registered trademark of SafeTCap Inc. and is not affiliated with any vehicle manufacturer for which its products are intended. SafeTCap® products are not endorsed by any vehicle manufacturers as OEM frame repair. Jeep, Wrangler, CJ, YJ, TJ, and the Jeep Grille Design are registered trademarks of Fiat Chrysler Automobiles (FCA). SafeTCap Inc., has no affiliation with FCA. Throughout our product line brochures the terms "Jeep," "Wrangler," "CJ," "YJ," and "TJ" are used for identification purposes only.*